

Development of Large-Capacity Single-Casing Reheat Steam Turbines for Single-Shaft Combined Cycle Plant

TAKASHI NAKANO*1
TAMIAKI NAKAZAWA*1
KENYU TAKEDA*1

KEIZO TANAKA*1
SHIN NISHIMOTO*1
TOSHIHIRO MIYAWAKI*2

Mitsubishi Heavy Industries, Ltd. (MHI) has developed large-capacity single-casing reheat steam turbine frames for single-shaft combined cycle plants using a large F or G series gas turbine. The single-casing of a steam turbine has numerous advantages, such as reduced cost resulting from reduced number of casings, simplified shaft system and arrangement, and enhanced operability and maintainability. This paper gives two examples of the high-efficiency single-casing steam turbine which are under manufacturing, the turbine designed for quick-start operation and capable of coupling with G-series gas turbines, and the world's largest-class axial-exhaust turbine applying the Synchro-Self-Shifting clutch. Their features and the advanced technologies used are introduced in the paper.

1. Introduction

Because of growing concerns about natural resource conservation and environmental problems, the constructions of gas turbine combined cycle power plants have been increasing since the 1980s as they have the advantage of high efficiency, low environmental load through the use of natural gas and excellent operability such as DSS. Steam turbines for the bottoming cycle of combined cycle plants had their unit capacity continuously increased as the combustion temperature of gas turbines became higher and unit capacity larger.

Against this background, the compact design of steam turbine, namely, single-casing turbine not only reduces the cost of the turbine itself, but reduces plant construction cost because of the reduced turbine size and shortens delivery time. The advantage of single-casing is particularly notable on the single-shaft combined cycle in reducing total shaft length, improving shaft system reliability due to the reduced number of rotors and enhancing operability and maintainability.

Based on the development of longer low-pressure last-stage blades, structural design technology and material technology, MHI has developed compact steam turbines for thermal power plants with reduced numbers of casings, including 600 MW class two-casing turbine. It has also developed large-capacity single-casing steam turbines for combined cycle plants to provide increased capacity. This paper describes the features of the new latest single-casing frames for single-shaft combined cycle plants and introduces the advanced technologies applied.

2. Steam turbine lineup for combined cycle plants

Two types of combined cycle plant include single-shaft where gas turbine (GT), steam turbine (ST), and generator are coupled on one shaft and multi-shaft where GT and ST are arranged in separate shafts, and are selected mainly based on plant operating conditions.

The multi-shaft type is necessarily selected for so-called 2 on 1 (or 3 on 1) configuration where the plant consists of two (or three) GTs and one ST. The steam turbine for these configurations is of 200 MW-class or higher output for combination with F-series or equivalent GTs, and two-casing turbine, which consists of a combined high- and intermediate-pressure casing and a double-flow low-pressure casing, is selected unless the condenser pressure is considerably high (Fig. 1).

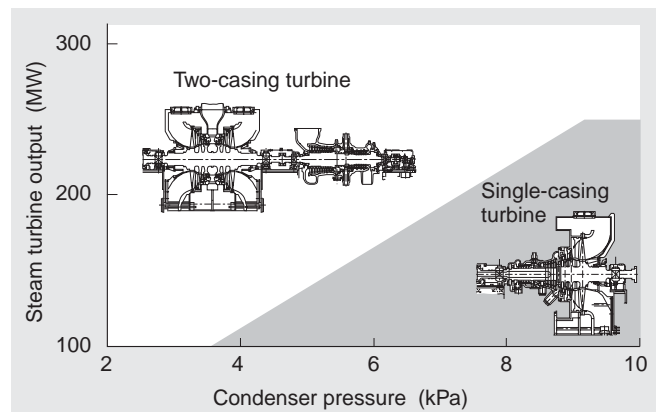


Fig. 1 Steam turbine capacity and casing arrangement
Indicates the applicable range of output and condenser pressure for single-casing turbines.

*1 Power Systems Headquarters

*2 Takasago Research & Development Center, Technical Headquarters

Since the types of GTs are limited and steam flow and steam conditions are generally limited in a same range, frames standardized for 60 Hz use and 50 Hz use are adopted in high- and intermediate-pressure turbines. Each standardized frame uses common designs and parts, including the material for casing and rotor, and only the design of the blade path is adjusted to cope with the variation in steam flow and steam conditions. This type of standardized frame enables to reduce the cost, shorten the delivery time, enhance reliability by repeated use of the same frame, and, at the same time, ensure the optimization of performance for the design conditions of each plant. For low-pressure turbines, the exhaust volumetric flow varies greatly because of different condenser pressure in each plant even though steam mass flow is the same. Therefore, the low-pressure turbine frame with optimum performance is selected from those standardized by each last-stage blade series.

For 1 on 1 configuration plants where the plant consists of one GT and one ST, the single-shaft type is often used where the GT, ST, and generator are coupled in a row. The steam turbine for this configuration is of 160 MW-class or lower, and either single-casing or two-casing turbine is used based on steam flow rate and condenser pressure. For 60 Hz use, the single-casing turbine is currently possible with the F-series GT through the development of long low-pressure end blades such as 40-inch steel blades. With the steam flow further increased in the G-series GT, which has come into wide use, MHI has developed a new larger-capacity single-casing turbine frame with 45-inch blade. For 50 Hz use, where the GT capacity is 1.3 to 1.5 times larger than the GT for 60 Hz use and generated steam is larger in volume, two-casing turbines have been used for F-series GT

except for high condenser pressure. However, MHI has developed a large-capacity single-casing turbine frame for F-series GT with long low-pressure end blades of 48 inch.

3. Single-casing reheat steam turbine for G-series GT providing high-efficiency and quick start

A large-capacity single-casing reheat steam turbine has been developed for single-shaft combined cycle plant using M501G GT for 60 Hz use. With the use of G-series GT, steam flow is greatly increased, compared with F-series GT, resulting in the increase of the exhaust loss of low-pressure end in the single-casing turbine even with 40-inch last-stage blades. Although two-casing design with the double-flow low-pressure turbine with 29.5-inch class last-stage blades can optimize the exhaust loss, disadvantages other than performance occur as explained above.

In the new turbine, a 45-inch titanium blade with larger exhaust area is used to maintain compactness of single-casing turbine and, at the same time, ensure high performance. The 45-inch blade has been tested at the model turbine test facility to verify performance and reliability during development stage, using the actual blade⁽¹⁾, and has been used in commercial unit since 2003.

Besides the above features, the new turbine uses the following technologies required for high performance, high reliability and operability.

3.1 Welded rotor for quick start

To meet the market demand for high temperature, large capacity, and shortened delivery time in a steam turbine plant, MHI has conducted R&D in basic technology for welded rotors and promoted its application to actual plants⁽²⁾. Fig. 2 shows materials construction and features on various types of welded rotors.

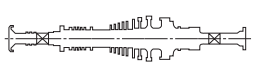
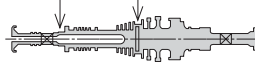
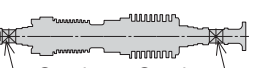
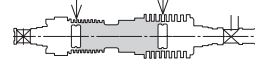

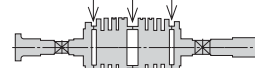
	Integral forged rotor	Welded rotor	Features of welded rotor
Combined HP-IP-LP rotor	 2 1/4CrMoV steel	 Welded joint High-temp. zone: 12Cr steel or 9Cr steel Low-temp. zone: 3.5NiCrMoV steel, 2 1/4 Cr MoV steel	Use of 12Cr steel or 9Cr steel in high-temp. zone and 3.5NiCrMoV steel for zone requiring high toughness improves high-temp. performance, enables large capacity and shortens delivery time. The large bore structure allows quick start operation.
HP-IP rotor	 Overlay welding Overlay welding 12Cr steel or 9Cr steel	 High-temp. zone: 12Cr steel or 9Cr steel Low-temp. zone: 2 1/4CrMoV steel	Restricted use of 12Cr steel or 9Cr steel to high-temp. zone improves high-temp. performance, enables large capacity and shortens delivery time.
Large LP rotor	 3.5NiCrMoV steel	 3.5NiCrMoV steel	Use of small parts enables large capacity and shortens delivery time.

Fig. 2 Materials and features of welded rotors

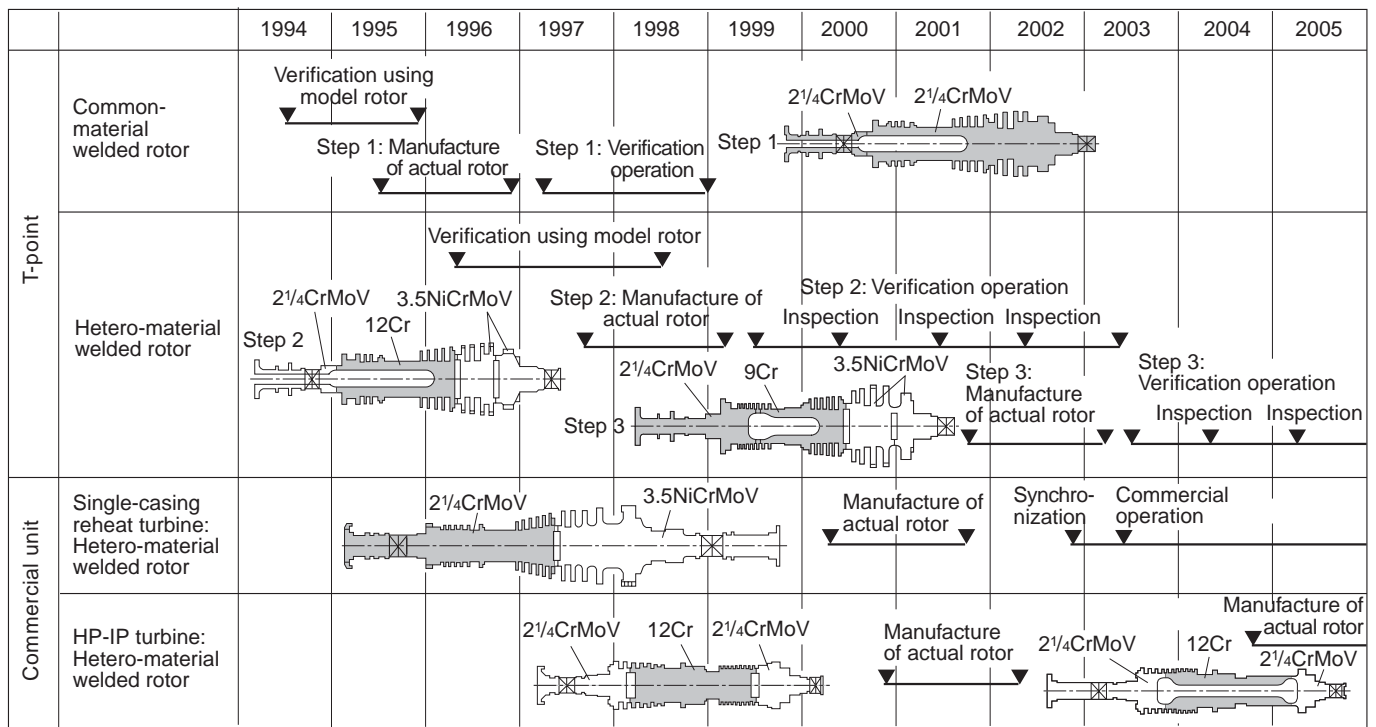


Fig. 3 Application of welded rotor to actual turbine

With steam turbine capacity increasing, rotor size has grown, which may cause difficulty in manufacturing due to the limitations in material dimensions, particularly for the manufacture of integral forged rotors made of 12% Cr or 9% Cr steel for high-temperature turbines or rotors for large low-pressure turbines. For welded rotors, larger rotors can be manufactured by welding small-size forged parts in a short delivery time. For welded rotors for high-temperature turbines, the application of expensive high-temperature material can be limited to the high temperature zone, and besides, low-alloy steel overlay welding that is required for journal section of integral forged rotors is omitted. In construction of a high-to-low-pressure integral rotor used for single-casing reheat turbines, materials best suited to particular operating temperature zones are combined by welding, for example, 12% Cr or 9% Cr steel at high temperatures requiring high-temperature strength and 3.5% NiCrMoV steel at low temperatures requiring toughness. Reliability of the entire rotor is then enhanced by selective use of materials.

Fig. 3 shows the application of the welded rotor in actual turbines. MHI has been conducting verification operation of welded rotor by common steel welding using 2-1/4 CrMoV steel starting from 1997, and by hetero-material welding since 1999 using the combination of 2-1/4 CrMoV steel-12% Cr steel-3.5 NiCrMoV steel-3.5 NiCrMoV steel and 2-1/4 CrMoV steel-9% Cr steel-3.5 NiCrMoV steel at the combined cycle verification plant "T-point" in Takasago factory.

Fig. 4 shows shaft vibration until the turbine reaches steady operation after a quick start, demonstrating excellent operation. Soundness of the welded joints was

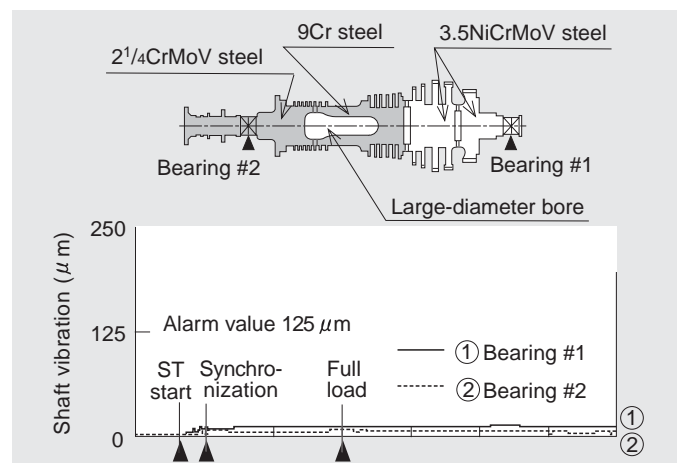


Fig. 4 Operations of large-bore hetero-material welded rotor at T-point Indicates small shaft vibration even at quick start.

confirmed by ultrasonic test, investigation of the microstructure, or internal visual inspection carried out during periodical overhauls. Based on these verification results, commercial unit with 130 MW steam turbine output using the hetero-material welded rotor of 2-1/4 CrMoV steel-3.5 NiCrMoV steel started the commercial operation in 2003, demonstrating stable operation. The new single-casing frame developed for combined cycle plants with G-series GT also uses the hetero-material welded rotor using high-temperature materials at the center section of the rotor. Taking advantage of the weld structure, a large bore structure is adopted for high-temperature section, which is the same structure adopted in T-point as shown in Fig.4. This structure reduces thermal stress generated in rotors at start-up, enabling quick starts and improving plant operability.

3.2 High-performance reliable low-pressure exhaust casing

The new turbine uses a downward exhaust casing and has bearings laid directly on the foundation to ensure shaft reliability. The LP side gland casing which is independent of the LP casing and connected to it through bellows also ensures reliability against casing deformation caused by vacuum loads, etc. The exhaust casing uses an asymmetrical flow guide to improve pressure recovery and reduce pressure loss.

3.3 High-performance technology

The steam inlet nozzle chamber has a scroll type passage with the aim of homogenizing the steam flow in circumferential direction and reducing pressure loss (Fig.5). High-efficiency blades which reduce unsteady loss caused by interference between rotating and stationary blades are used for HP and IP blades. The Active Clearance Control (ACC) seals employed for the dummy ring reduce leakage loss. On this type of seal, the seal segments are raised by a spring force to keep the clearance between the rotor and the seal fins large when the turbine is starting, stopping or after stopped, while they are shifted to the regular position toward the center until the proper radial clearance is maintained when the turbine operates under loaded condition, utilizing the pressure difference. The directly lubricated bearing reduces mechanical loss.

4. World's largest-class axial-exhaust single-casing reheat steam turbine using an SSS clutch

A single-casing reheat steam turbine for single-shaft combined cycle plants using M701F GTs for 50 Hz use has been developed (Fig. 6). For the M701F, the conventional two-casing steam turbine was used, except for high con-

denser pressure, because of high flow rate of exhaust steam. In the new turbine, the world's longest 48-inch steel blade for 3000 rpm turbines is used at the low-pressure last-stage, which enabled the use of single-casings for the turbine even for low condenser pressure condition and realized the largest-class single-casing reheat steam turbine. The 48-inch blade has been used in commercial unit since 2004, and reliability has been confirmed. Besides the above features, the new turbine uses the following technologies for high performance and flexible operation.

4.1 Use of SSS clutch

The shaft using the new steam turbine consists of GT and ST connected to both ends of the generator, with the synchro-self shifting (SSS) clutch installed as a coupling between the generator and steam turbine, ensuring the following operating advantages:

- Changeover of the operation between the GT simple cycle and a combined cycle is possible, enhancing the flexibility of the plant operation.
- Since the steam turbine does not conduct high-speed rotation until ST start conditions are established after the GT starts, no cooling steam for preventing overheating of ST is necessary, reducing equipment cost of the plant and improving operability.

As shown in Fig. 7, the SSS clutch is used in the steam turbine of single-shaft combined cycle plants coupled with M501F GT and a generator, and has been operating since 2003. Before use the clutch in actual turbines, lubrication to the clutch was verified by the testing using actual turbine bearing. Comprehensive reviews were also made such as analysis of bending and torsional vibration of the shaft at clutch engaging as shown in Fig.8.

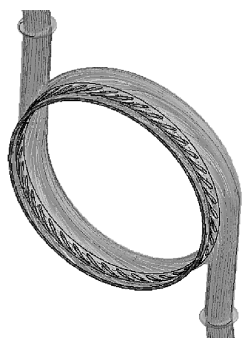


Fig. 5 Scroll type steam inlet
Indicates result of CFD analysis in steam path.

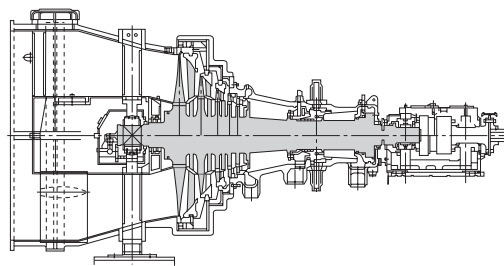


Fig. 6 Large-capacity axial-exhaust single-casing reheat turbine
3000 rpm, 48-inch steel blade used for last-stage blade.

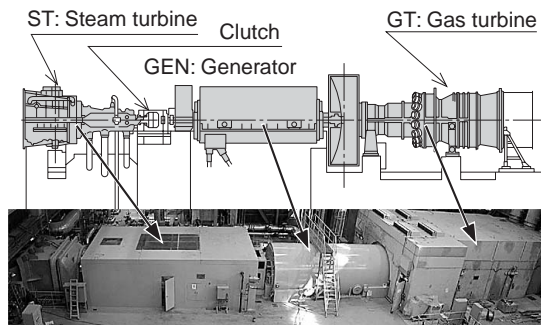


Fig. 7 Turbine shaft arrangement applying SSS clutch
Clutch is installed between steam turbine and generator.

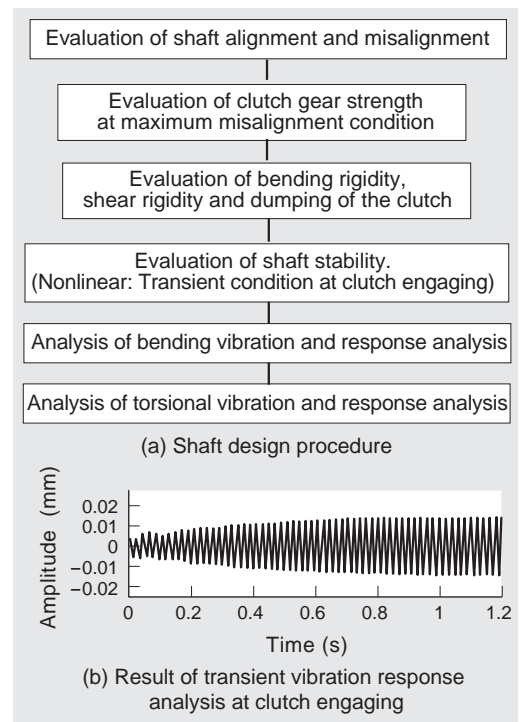


Fig. 8 Design of shaft system including SSS clutch

Furthermore, comprehensive measurement was done at plant site for shaft vibration, eccentricity, inclination and bearing temperature, etc. **Fig. 9** shows steady shaft vibration before and after clutch engaging, proving excellent operation. Satisfactory results of such operation confirm the applicability of the SSS clutch to new larger-capacity steam turbine developed for the plants with M701F GT.

4.2 High-performance axial-exhaust casing

The shaft arrangement above enables axial-flow exhaust of the steam turbine. This in turn dramatically reduces exhaust loss using a high-performance axial-exhaust casing with higher pressure recovery than with downward exhaust. Axial-exhaust, where the condenser can be installed on the same floor, enables lower the turbine deck and building, compared to downward exhaust where the condenser is installed underneath the steam turbine,.

4.3 High-performance technology

High performance is obtained through the scroll structure of the steam inlet, use of the ACC seal on the dummy ring, etc.

5. Conclusions

Large-capacity single-casing reheat steam turbines have been developed to meet the need for large-capacity single-shaft combined cycle plants and the market demand for reduced cost by using compact machines, enhanced flexibility of the operation, and high performance.

The main basic technologies making the development possible are large LP last-stage blades, welded rotors, and the design technique of the shaft system including the SSS clutch and/or corresponding to bearing spans enlarged by the increased turbine capacity. These technologies have been comprehensively and practically verified in actual turbine, ensuring high reliability.

MHI will continue to develop new frames for steam turbines for combined cycle plants whose demand is expected to increase, through the application of new technologies to improve efficiency and reduce construction cost.

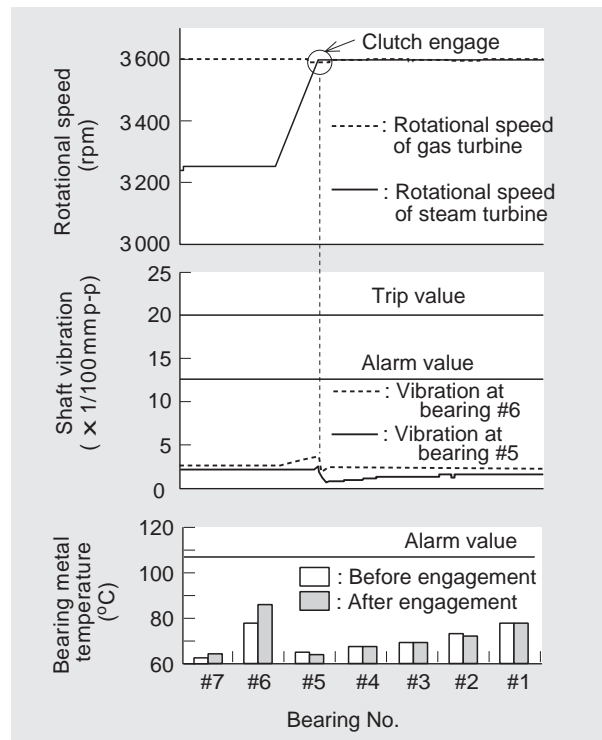


Fig. 9 Operation of turbine using SSS clutch
Indicates changes in shaft vibration and bearing metal temperature before and after clutch engagement.

References

- (1) Watanabe et al., Development of High Efficiency and Reliability Low Pressure End Blade, Mitsubishi Juko Giho Vol. 38 No. 2 (2001)
- (2) Shige et al., Development of Large-Capacity, Highly efficient Welded Rotor for Steam Turbines, Mitsubishi Heavy Industries Technical Review Vol. 38 No. 1 (2001)



Takashi Nakano



Keizo Tanaka



Tamiaki Nakazawa



Shin Nishimoto



Kenyu Takeda



Toshihiro Miyawaki