

# Service Middleware for Performing and Optimizing On-site Work

● Tsuneo Katsuyama ● Youji Kohda

*(Manuscript received April 20, 2007)*

**The growing importance of services is placing greater emphasis on company worksites as points of contact with customers. Although back-end enterprise systems are the foundations of differentiated services, they often become too large and complex to keep pace with changing customer service needs. Consequently, worksite employees must bear the burden of satisfying these needs. Service middleware, which should become the basis of IT solutions for on-site work, consists of an execution layer for worksite employees and an optimization layer for worksite managers. The execution layer supports enterprise systems, worksite sensors, and equipment to help worksite employees concentrate on the tasks of achieving high value. The optimization layer optimizes the execution layer for dealing with changing customer service needs and evolving enterprise systems. This paper outlines Fujitsu's service middleware used to perform and optimize on-site work.**

## 1. Introduction

There has been an obvious evolution from production to services. In the age of production, products were sold immediately after being produced. In the age of services, products are sold as part of solutions, and the key to enhancing business competitiveness is the ability to promptly provide services that meet specific customer needs.

The back-end enterprise system — the foundation of a company's strength — has become more important in the age of services. Various enterprise systems have already been added to offer diversified services. However, such individual development of enterprise systems complicates the adjustments made between individual enterprise systems, and makes it difficult to keep pace with changing customer service needs. Consequently, worksite employees must bear the burden of satisfying these needs. This growing burden on worksite employees adversely affects work efficiency and customer satisfaction,

as well as exhausting those employees.

Fujitsu has promoted the research and development of service middleware to solve these problems. Service middleware should become the basis of IT solutions for on-site work.

This paper outlines the execution and optimization layers of Fujitsu's service middleware.

## 2. Domain of service middleware applicability

**Figure 1** shows the domain of service middleware applicability. Worksite employees working for a service provider use back-end enterprise systems to offer services to customers. The front server and terminals are used as business tools to assist worksite employees in mastering back-end enterprise systems. The front server helps worksite managers analyze and optimize on-site work. Specifically, the front server collects the input data stored on the terminals of worksite employees or sensed by worksite

equipment and sensors. The front server can not only be a physical server at a worksite, but also a service provided via computer networks. Although such servers are now generally provided as physical servers, expectations are for more front servers to be provided via computer networks in the future.

### 3. Configuration of service middleware

Service middleware consists of an on-site work execution layer for worksite employees and an on-site work optimization layer for worksite managers.

Worksite employees perform work to satisfy customer service needs and are expected to concentrate on such tasks as solving customer problems to achieve high value as much as possible. The execution layer combines enterprise systems or sensors and equipment installed at worksites, and assists worksite employees in

performing on-site work of high added value.

As customer service needs change, on-site work is progressing from day to day. Enterprise systems are also progressing although the progress is slower than that of on-site work. The optimization layer is used to optimize the execution layer in keeping pace with changing customer service needs and the ongoing development of enterprise systems.

Fujitsu is currently applying service middleware to the enterprise systems used for maintenance. The execution layer is now the installation phase of practical maintenance work. Since the optimization layer remains in the design phase, this paper only refers to its basic framework.

### 4. On-site work execution layer

This chapter describes the two technologies that support the on-site work execution layer: offline continuation processing and cross-sectional

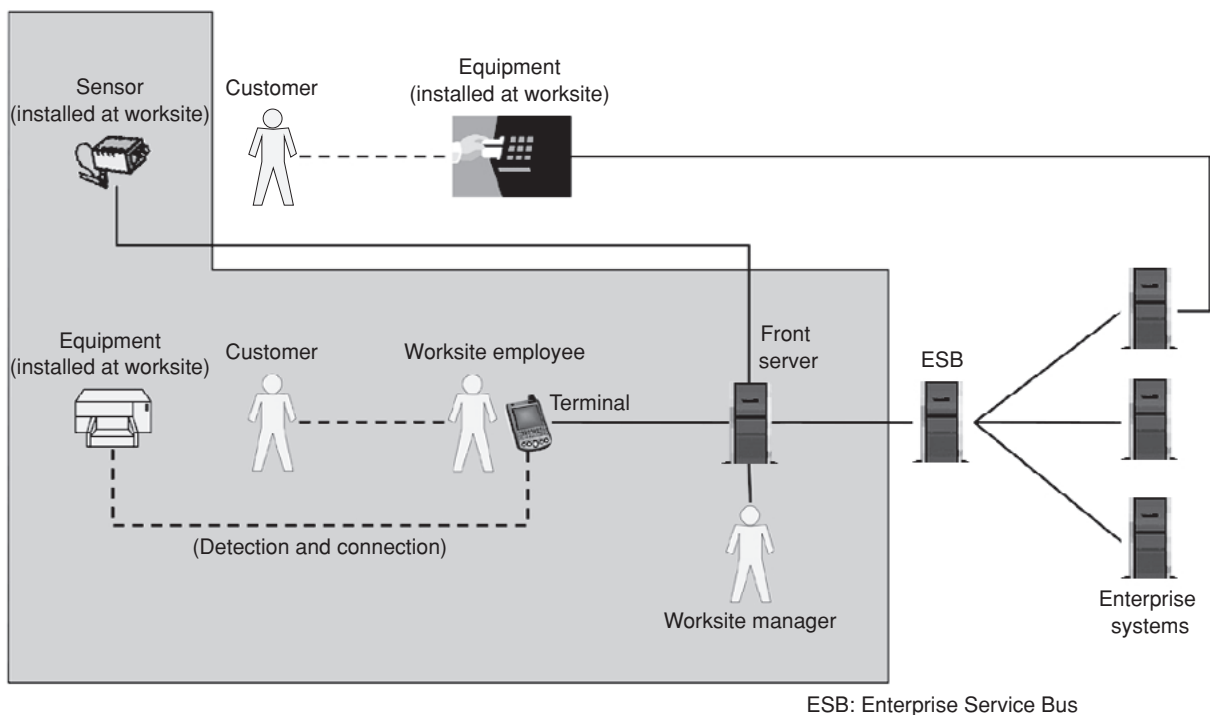

Figure 1  
Domain of service middleware applicability.

linkage.

#### 4.1 Offline continuation processing technology

Offline continuation processing technology allows worksite employees to continue working using terminals alone even when disconnected from the front server. Although the Internet is increasingly a part of modern life, networks are often unavailable on worksites. For example, a customer engineer dispatched to a customer site may be unable to connect his/her terminal to the company due to security reasons while working at the customer site. Such a case requires offline continuation processing.

To perform offline continuation processing, a terminal must be provided with a local business application and local DB in order to continue offline processing all by itself. Upon going online, the terminal's local DB and the front server's DB must be synchronized. In offline continuation processing, it is assumed that the DBs only store data like electronic slips manipulated through a single entry, such as by the person entering the data. In synchronous processing, electronic slips created by an enterprise system are passed to the terminal's DB through the front server's DB. Electronic slips created by a terminal are passed to an enterprise system from the terminal's DB through the front server's DB. Moreover, the front server must have a remote management mechanism to keep the local business application up to date.

Because worksite equipment cannot be accessed via networks in offline processing, dynamic equipment linkage technology is very useful. This technology allows worksite employees to dynamically detect equipment and sensors around the terminal for use via local communication. In offline processing, the data collected from the worksite equipment and sensors via local communication is stored in the terminal's local DB. Upon going online, the front server DB is synchronized with that data.

Fujitsu has promoted the research and development of techniques involving dynamic equipment linkage technology. These include the task computing technology<sup>1)</sup> based on the semantic Web for service descriptions and plug & service capability based on an ad hoc wireless LAN. Fujitsu has recently prototyped a service that detects a worksite display unit with a mobile terminal using dynamic equipment linkage technology, and directly transfers video stored on an online device to the display unit under mobile terminal control.<sup>2)</sup>

The lack of standard technology has posed a barrier to the spread of dynamic equipment linkage technology. The digital living network alliance (DLNA)<sup>3)</sup> guidelines have recently generated high expectations for such standard technology. DLNA 1.0 and its extended guidelines have already been formulated and DLNA 2.0 is in progress. Leading domestic makers of consumer electronics have announced their intention to provide DLNA-compliant products. In fact, such products are beginning to become popular.

#### 4.2 Cross-sectional linkage technology

Cross-sectional linkage technology allows worksite employees to reduce their work hours when multiple enterprise systems must be used to meet complex customer requests.

Consider a case where data is exchanged between enterprise systems and worksites in the form of slips. Worksite employees previously had to fill out different slips as required for the number of enterprise systems. The employees had to bear the burden of ensuring consistency between multiple slips. If inconsistent slips were sent to enterprise systems, individual enterprise systems could not check for inconsistency, which increased the cost of subsequent troubleshooting.

The cross-sectional linkage technology employed for Fujitsu-developed service middleware can solve this problem using an integrated slip developed in accordance with practical

on-site work. This integrated slip is a virtual one on which items required for present work have been semantically consolidated among the items listed on multiple slips. Cross-sectional linkage technology is used to collect slips from multiple enterprise systems and generate an integrated slip. This technology also disassembles the integrated slip on which worksite employees have entered data, and creates multiple slips that each enterprise system can understand. It can be said that cross-sectional linkage technology mutually converts an integrated slip required by worksite employees and individual slips required by back-end enterprise systems.

**Figure 2** shows the architecture of cross-sectional linkage technology. A general-purpose XML-based specification such as universal business language (UBL),<sup>4)</sup> which is not dependent on the category of industry, is used for the integrated slip. The architecture consists of two modules. In one module, slips from enterprise systems are written to the XML integrated slip with tags added by items. In the other module, the integrated slip is disassembled into slips to be passed to enterprise systems according to tags added to the integrated slip. The module groups are connected in a pipeline configuration. Each module can be added or deleted with Plug & Play according to the addition and deletion of enterprise systems.

Dictionaries are shared between enterprise systems and worksites in order to standardize terminology. Revising these dictionaries can reduce the human resources needed for worksite data entry and improve the quality of data to be entered for enterprise systems. Analyzing the data of the flowing slips and data entered by worksites, and reviewing the items in the dictionaries make such revision possible.

## 5. On-site work optimization layer

This section describes the two technologies that support the on-site work optimization

layer: analytical processing plug-in linkage and worksite operation optimization.

### 5.1 Analytical processing plug-in linkage technology

Analytical processing plug-in linkage technology enables worksite employees to maximize the analytical capability provided by available analytical techniques, since the plug-in mechanism of this technology has achieved universal combinations of analytical techniques. **Figure 3** shows an example of analytical processing plug-in linkage technology. This mechanism also supports the worksite operation optimization technology described below. The technology consists of a step to set up sensors for collecting worksite data, a step to preprocess the sensor data, and a step to integrate the preprocessed data of multiple sensors in a cross-sectional manner.

The sensors assumed include such hardware sensors as cameras and RFID readers, software sensors to collect the operation logs of enterprise systems, and consumer generated media (CGM) sensors to collect blog data. The preprocessing step profiles the capabilities of analytical techniques and the input-output data formats, and thus makes it easy to add new analytical techniques. The integration step is a modeling step to describe the structural relations between the data of multiple sensors. Typical modeling methods include a mathematical model based on a statistical approach and a machine-learning model based on a computing approach.

### 5.2 Worksite operation optimization technology

Worksite operation optimization technology allows worksite managers to compare multiple worksites, transplant operations of the worksite offering the best performance, and optimize the performance of each worksite. If a worksite with considerably different on-site work features is set as a target, its operations may not be

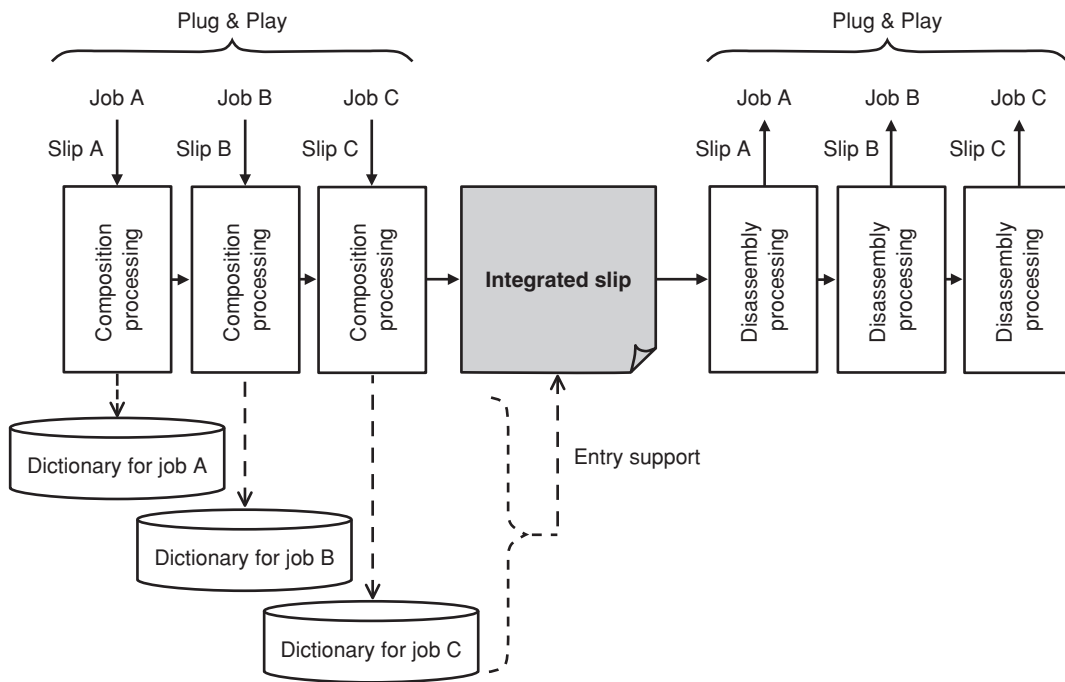

Figure 2  
Cross-sectional exchange pipeline.

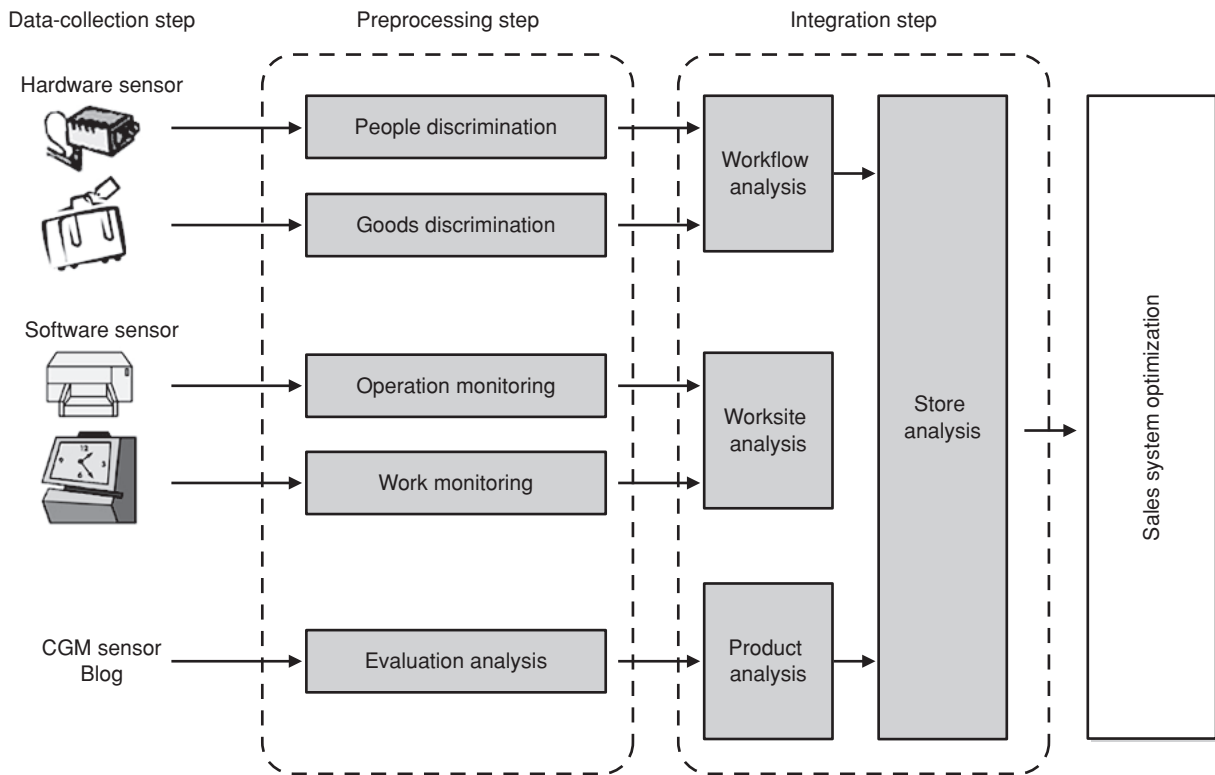

Figure 3  
Example of analytical processing plug-in connection.

successfully transplanted and work the other way. Therefore, setting a target worksite entails collecting and categorizing the worksites having similar features, and then selecting the one offering the best performance among the categorized worksites. The procedure below is used to optimize worksite operations (**Figure 4**).

1) Categorization

Collect worksites similar to the target worksite. For example, analyze POS data and categorize the worksites for each type of store (urban or suburban). For an urban target worksite, collect the urban stores.

2) Model analysis

Analyze the time-series data that indicates the performance of worksites belonging to the same category as the target worksite, and then build a time-series prediction model for the performance of worksites in that category. In the example above, collect the POS data of urban stores and build a time-series prediction model

that reproduces how products are sold in those urban stores. Building a time-series prediction model is no easy task, but a model is likely to be detected since worksites were categorized in step 1.

3) Business optimization

Select a worksite offering the best performance among those belonging to the same category as the target worksite. Operations found on the worksite having the best performance are candidate operations to be transplanted to the target worksite. Worksite managers perform this transplant by selecting worksite operations that may be directly linked to worksite performance. In the example above, the store's attitude toward customers or its method of merchandise inventory control can be transplanted. Investigate the actual conditions under which the store's attitude toward customers enhances performance at the urban store having the best performance. Also investigate the actual conditions under which the

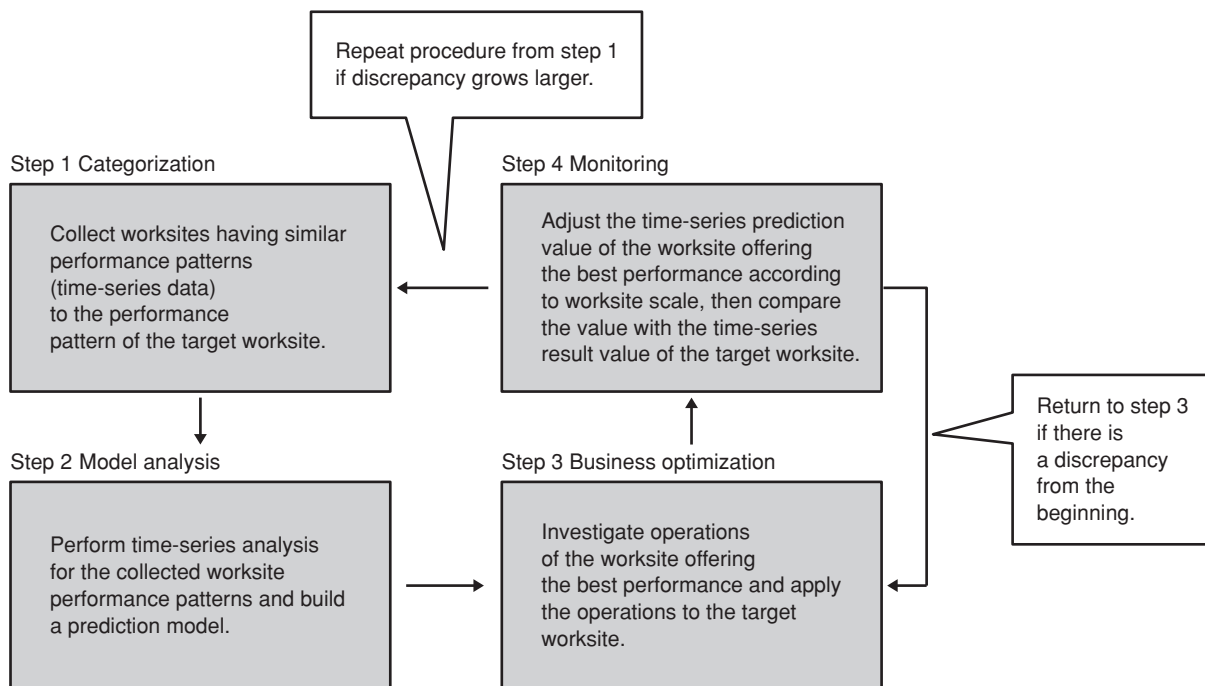

Figure 4  
Flow of worksite operation optimization.

store's inventory control enhances performance of the urban store having the best performance. Then attempt to transplant those actual conditions found to the store operations of the target store.

#### 4) Monitoring

Adjust the prediction value of the worksite having the best performance to the scale of the target worksite, and then compare the adjusted value with the resultant value of the target worksite in a time-series. Should the discrepancy between the values be minor, optimization can be considered to progress favorably. In the example above, after transplanting the attitude toward customers and product lineup of the store having the best performance, should the sales of the target store per floor space subsequently approach that of the store having the best performance, optimization can be considered to have progressed successfully. Conversely, any discrepancy from the beginning may result in worksite operations not being successfully transplanted. In this case, repeat the procedure from step 3. If the discrepancy grows larger over the passage of time, the environment surrounding the target worksite may have been changed. In this case, repeat the procedure from step 1.



**Tsuneo Katsuyama**, *Fujitsu Laboratories Ltd.*

Mr. Katsuyama received the B.S. and M.S. degrees in Instrumentation Engineering from Keio University, Yokohama, Japan in 1974 and 1976, respectively. He joined Fujitsu Laboratories Ltd., Kawasaki, Japan in 1976, where he has been engaged in research and development of communication systems/services and Internet

services middleware. He is a member of the Institute of Electronics, Information and Communication Engineers (IEICE) of Japan and the Association for Computing Machinery (ACM).

E-mail: katsuyamatsuneo@jp.fujitsu.com

## 6. Conclusion

The growing importance of services is placing greater emphasis on company worksites. This paper described the execution and optimization layers of service middleware. Service middleware, which should become the front-end of back-end enterprise systems, provides an execution layer for worksite employees and an optimization layer for worksite managers.

Fujitsu is now applying service middleware to the enterprise systems used for maintenance, with the execution layer currently in the installation phase. Since the optimization layer remains in the design phase, this paper only refers to its basic framework.

## References

- 1) R. Masuoka et al.: Task Computing — The Semantic Web meets Pervasive Computing. ISWC 2003, LNCS 2870 Springer-Verlag, 2003, p.866-881.
- 2) T. Mohri et al.: User-Centric Computing with Cellular Phones and Information Appliances. (in Japanese), *FUJITSU*, 58, 2, p.129-134, (2007).
- 3) Digital Living Network Alliance.  
<http://www.dlna.org/>
- 4) OASIS Universal Business Language TC.  
[http://www.oasis-open.org/committees/tc\\_home.php?wg\\_abbrev=ubl](http://www.oasis-open.org/committees/tc_home.php?wg_abbrev=ubl)



**Youji Kohda**, *Fujitsu Laboratories Ltd.*

Mr. Kohda received the B.S. degree in Information Science and the M.E. and Dr. Eng. degrees in Information Engineering from the University of Tokyo, Tokyo, Japan in 1981, 1983, and 1986, respectively. He joined Fujitsu Ltd. in 1986 and moved to Fujitsu Laboratories Ltd. in 1990. He has been engaged in research and development of the Fifth Generation

Computer Systems Project, instant messaging, and Internet services middleware. He is a member of the Information Processing Society of Japan (IPSJ), the Institute of Electronics, Information and Communication Engineers (IEICE) of Japan, and the Japan Society for Software Science and Technology (JSST).

E-mail: kohda.youji@jp.fujitsu.com